

# Micro Resolution Chart for X-Ray

## JIMA RT RC-02B

*Price 180,000 Yen  
plus shipping charge*

Micro-focus type of X-ray inspection systems are currently in common use. The micro-chart is most indispensable to adjust focus-point ( size / shape ) for X-ray images. In genera, it is necessary to maintain the capability of X-ray systems . This micro-chart has been fabricated by using the latest semiconductor lithography techniques. As the result, sub-micron slits down to 0.4 micron could be achieve. (0.4, 0.5, 0.6, 0.7, 0.8, 0.9, 1.0, 1.5, 2.0, 3.0, 4.0, 5.0, 6.0, 7.0, 10.0, 15.0  $\mu\text{m}$ , 16 different width) JIMA ( Japan Inspection Instruments Manufacturers' Association ) has succeeded to supply with an economical price by quantity produce.

### Line and Space Pattern

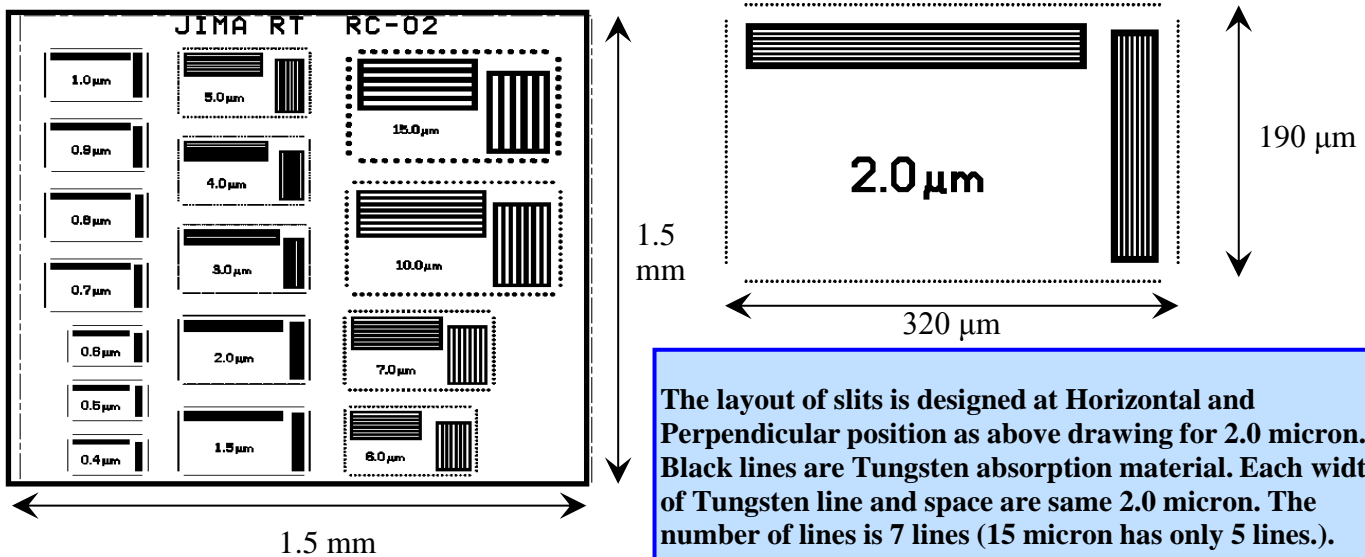

The layout of slits is designed at Horizontal and Perpendicular position as above drawing for 2.0 micron. Black lines are Tungsten absorption material. Each width of Tungsten line and space are same 2.0 micron. The number of lines is 7 lines (15 micron has only 5 lines.). The outer edge is surrounded by wider line of Tungsten.

### Cross Section (Si Base thickness: 60 micron)

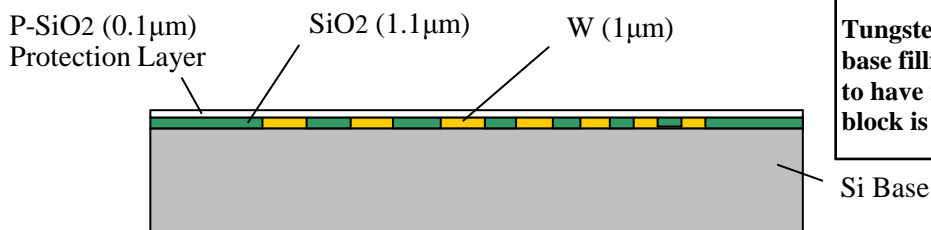

Tungsten chart is drawn on 5 mm square Si base filling the gap with SiO<sub>2</sub>, then polished to have nearly 1 micron thickness. And Si block is fixed on 30x40 mm Aluminum plate.

### Specification

1. Whole Size: 40x30x5 mm
2. Si Plate: 5x5x0.06 mm
3. Absorption Material: Tungsten (W) 1.0 $\mu\text{m}$  Thickness
4. Protection Film: Pycarbonate 0.1 mm Thickness
5. Tolerance of Slit width and space: +/- 10% or less under 2 $\mu\text{m}$ , +/- 8% or less over 3 $\mu\text{m}$  (At 23 degree C)
6. Slit Width: 0.4, 0.5, 0.6, 0.7, 0.8, 0.9, 1.0, 1.5, 2.0, 3.0, 4.0, 5.0, 6.0, 7.0, 10.0, 15.0 $\mu\text{m}$ , 16 size
7. Number of Slit: 7 (Only 15 $\mu\text{m}$ : 5)
8. Protection Case included  
Micro-Chart, Certification, Operation Manual
9. Operation Temperature Range: 10 $^{\circ}\text{C}$  to 70 $^{\circ}\text{C}$

**NOTE:**  
RC-02B has same chip as RC-02, but has modified aluminum base plate.



## JIMA RT RC-02B

### ■ Micro-Chart (Reversed side)



### ■ Protection Case



### ■ Outer Drawing (Top side)

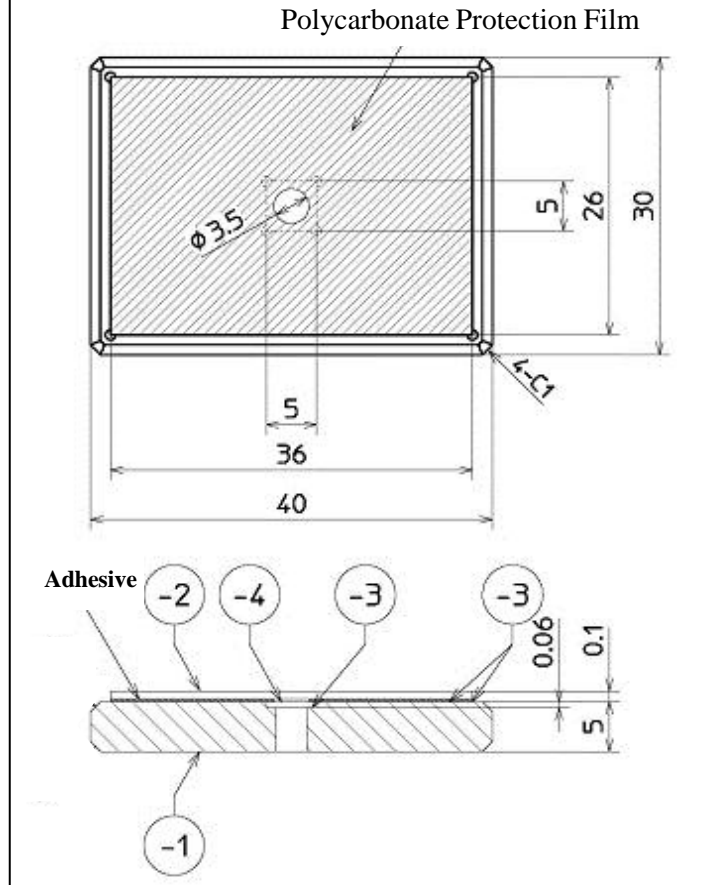

No.	Parts	Material	Size(mm)
-1	Aluminum Plate	A2017P	40x30x5
-2	Protection Film	Polycarbonate	36x26x0.1
-3	Adhesive Material	Silicon	included above
-4	Silicon Base	S	5x5x0.06
	Absorption Material	W	t=1.0μm

### Ordering:

Please send Purchase Order Sheet. We will send invoice for advanced payment.

We will ship within 10 days after confirmation of your remittance.

**Note: Bank Charge and Shipping Charge should be paid by the customer.**

### (Questions / Ordering to:)

#### RT Test Piece / Microchart

TEL : 03-5288-5080 FAX : 03-5288-5081

E-mail: rtp@jima.jp

Specification can be modified without any previous notice. Please confirm.

### Exclusively Sold by: